



MISAILIDI FOUNDRY

FOUNDRY: 7.5th KM OF THESSALONIKI – KAVALA

INDUSTRY: PERIVOLAKI LAGKADA

Tel. 2394020799 – Fax 2310681033

www.tzaki.com.gr - e-mail: info@misailidi.gr

**INSTRUCTIONS FOR USE AND SAFETY INFORMATION
FOR NATURAL FLOW STOVE WITH BOILERS
(HYDRAULIC FIREPLACES)**

TABLE OF CONTENTS

1. Introduction	4
1.1 Company details	4
1.2 Product description and technical specifications	4
1.3 Purpose and scope	5
1.4 Scope	5
1.5 Importance and safety instructions	5
1.6 General safety recommendations	6
1.7 Fire hazard	7
1.8 Use and terms of use	7
2. Transport	7
2.1 Potential risks during transportation	7
2.2 Proper packaging methods	8
2.3 Precautions during installation and transportation to high altitudes	8
2.4 Hazard marking and warnings	8
3. Installation	8
3.1 Potential risks during installation	8
3.2 Installation instructions	9
4. Tips for proper operation	11
5. Handling means	12
5.1 Adjusting the incoming combustion air flow	12
5.2 Flue gas flow adjustment	12
6. Device operation	13
6.1 Turning on the device	13
6.2 Operation under normal conditions	14
6.3 Extinguishing a fireplace	14
6.4 Operation during the transition period	14
6.5. Feedback	14
7. Maintenance	15
7.1 Potential hazards during maintenance	15
7.2 Protective measures during maintenance	15
7.3 Cleaning and maintenance	15
8. Removal, disassembly and demolition	17
8.1 Potential risks	17
8.2 Protective measures during uninstallation	17
8.3 Materials and Tools Required for Uninstallation	18
8.4 Potential risks during deconstruction and demolition	18
9. Information in case of damage or danger	18
9.1 Generally	18

9.2 In case of a chimney fire	18
9.3 In case of power outage	18
9.4 Possible faults and causes	19
10. Warranty	20

1. Introduction

1.1 Company details

COMPANY NAME	MISAILIDI FOUNDRY
ADDRESS	FOUNDRY: 7.5th KM OF THESSALONIKI – KAVALA INDUSTRY: PERIVOLAKI LAGKADA
CONTACT DETAILS	Tel. 2394020799 – Fax 2310681033 e-mail: info@misailidi.gr
WEBSITE	www.tzaki.com.gr

1.2 Product description and technical specifications

The device must be used exclusively for heating the interior spaces of buildings (except bedrooms) that meet the provisions of the Building Regulations and other relevant legal and regulatory provisions.

The device has an inlet air adjustment lever (primary air). At the same time, on the back of the firebox as well as in the frame of the firebox there are holes for the flow of secondary and tertiary combustion air respectively.

The body of the device is lined with a double steel wall, forming the boiler in which water circulates, which is heated during use of the device and is led through the central heating installation to the radiators for heating the spaces they serve.

The ceramic glass of the door is resistant to up to 750°C, allowing visual contact with the combustion chamber without the need to open the door.

The device is used exclusively for heating indoor spaces of buildings (excluding bedrooms) that meet the provisions of the General Code of Civil Procedure, the ELOT Standard HD 384 and other relevant provisions.

The natural draft fireplace with boiler consists of the following main parts:

- Steel combustion chamber with integrated water boiler.
- Door with ceramic glass.
- Sliding door mechanism with sliding guides and counterweight.
- Fixed flue gas deflector inside the firebox
- Incoming air flow adjustment lever (primary combustion air).
- Secondary combustion air device, located on the back of the firebox.
- Tertiary combustion air device, located on the frame of the firebox.
- Flue gas outlet diaphragm (damper) adjustment lever.
- Ashtray under the firebox for collecting ash.
- Connection sockets for hydraulic equipment for water supply, drainage and evacuation.

Also, the device has the ability to work with pipelines for:

- The entry of primary combustion air from the external environment and
- The exit of flue gases from the combustion space to the external environment.

The types of natural flow stoves with boiler and their technical characteristics are presented in the tables below:

	HYDRO 80 FLAT	HYDRO 80 PRISMA	HYDRO 90 FLAT
NOMINAL THERMAL POWER (kW)	21,03	23,88	24,01
NOMINAL THERMAL WATER POWER (kW)	13,0	14,0	16,8
RADIANT THERMAL POWER (kW)	10,52 – 31,55	11,94– 35,81	12,01– 36,02
THERMAL POWER RANGE (kW)	79,49	75,77	76,0
EFFICIENCY (%)	6,13	7,30	7,32
NOMINAL FUEL CONSUMPTION (Kg/h)	223	223	262
AVERAGE FLUE GAS TEMPERATURE (oC)	0,1155	0,1079	0,1080
CO CONCENTRATION AT 13% O2 (%)	250	250	250
FLUE DIAMETER (mm)	275	294	320
WEIGHT (Kg)	184x87,7x64	188x94x78,4	188x97x70

1.3 Purpose and scope

The purpose of this document is to provide detailed information and guidance to ensure safety during the various phases of the life cycle of solid fuel fireplaces. It identifies hazards, protective measures, and procedures required for the safe handling of these products.

Solid fuel fireplaces require special care during installation, use, maintenance, as well as during dismantling or demolition, in order to ensure their safety and efficiency throughout their life. The manufacturer provides specific instructions for all these procedures, as well as for the risks associated with their operation.

1.4 Scope

The scope of application covers the transportation, installation, use, operation, removal, maintenance, dismantling and demolition of solid fuel fireplaces, and is addressed to consumers, installers and maintainers..

1.5 Importance and safety instructions

Safety at all stages of the product life cycle is crucial to avoid accidents, damage and risks to health and the environment. Each stage must follow strict guidelines to ensure the safety of users and professionals involved.

The safety requirements for fireplaces concern both professionals (workers) and non-professionals (consumers, users) at all stages of the product life cycle. During transport, installation, maintenance, use or dismantling, strict adherence to technical specifications and safety rules is required to reduce the risks of accidents, such as fire, carbon monoxide poisoning or damage to users and the environment. In particular, professional installers and maintainers must have the necessary knowledge and certifications to ensure the correct operation and safety of fireplaces. For consumers, it is important to use the fireplace correctly, to carry out regular maintenance and to follow the operating instructions in order to avoid accidents. Also, in the case of processing the product at the end of its life cycle, attention is required to the safe dismantling and recycling of the materials, in order to prevent pollution and to ensure the protection of the environment and public health.

These installation and operating instructions are intended for users and qualified technicians. We recommend that users read all the instructions for use carefully. The installation work and the first use of the fireplace must be carried out exclusively by a qualified technician.

Danger :



Failure to follow the safety instructions may result in serious injury – even death – as well as material and environmental damage. Read the safety instructions and follow the instructions they contain.

- Please read these fireplace installation and operating instructions carefully.
- Keep these instructions for future reference.

Proper installation, regular maintenance and safe use of solid fuel fireplaces are essential to ensure their efficient and safe operation. It is crucial to follow the manufacturer's instructions and take appropriate measures to avoid risks such as carbon monoxide poisoning, fires and mechanical damage. In the event of damage, professional assistance should be sought to properly repair the product.

This appliance is not intended for use by persons (including children) with reduced physical, sensory or mental capabilities, or lack of experience and knowledge, unless they have been given supervision or instruction concerning use of the appliance by a person responsible for their safety.

Children must be supervised to ensure that they do not use the appliance as a toy.

1.6 General safety recommendations

The device must be operated in accordance with this technical manual. The equipment used with the device must be suitable and have the required certifications, where required by applicable laws & regulations.

IT IS FORBIDDEN to operate the device without the guards in their intended position.

Any maintenance or repair work must be carried out only by qualified technical personnel with the approval of the manufacturer or its representative. Any maintenance or repair work must only be carried out after the device has been isolated from its power supply source and has cooled to ambient temperature.

ATTENTION!

Any electrical work must be carried out by a licensed electrician in accordance with applicable legislation. The spare parts that may be used must be approved by the manufacturer.

ATTENTION!

The installation and operation of the device in bedrooms should be avoided. It is recommended that the hot air ducts do NOT end in areas used as bedrooms. Otherwise, an appropriate detection and warning system for flue gas leaks should be installed.

The fireplace can be transported safely using the appropriate means.

The various parts of the appliance, especially its external surfaces, are extremely hot during operation and therefore the necessary precautions must be taken.

- Use suitable gloves.
- Inform your children about the risk of burns when the fireplace is in operation and make sure they stay at a safe distance, supervising them.
- Do not place objects that are not heat-resistant near the appliance.
- Do not place flammable or explosive materials near the appliance. In case you want to carry out work with flammable materials in the surrounding area, turn off the appliance and wait for it to cool down before carrying out these works.
- The appliance must not be altered or modified in any way.
- Use only genuine spare parts from the manufacturer. The company is not responsible for any damage caused by spare parts not approved by the company.

! Never leave children alone or unsupervised near the fireplace when it is in use.

! Teach children how to handle the fireplace correctly and safely.

! Do not touch the external surfaces and glass when the fireplace is in use, there is a high risk of burns.

! It is forbidden to use the fireplace as a waste incinerator.

- ! Do not burn used or painted wood.
- ! Dispose of ashes only after they have cooled completely.
- ! Ashes must be placed outdoors or disposed of in a place where there is no risk of ignition.
- ! Immediately inform your local specialist dealer if you detect any malfunction.
- ! Do not use chemicals or liquids to light a fire.
- ! Do not use ANY other fuels than those indicated.

1.7 Fire hazard

Fire prevention measures

1. The appliance must not be operated with the combustion chamber door open.
2. There must be no flammable or heat-sensitive objects or materials within 100cm of the burner.
3. Safety distances must be maintained at all times. Within these safety distances from the appliance, no flammable objects must be placed.
If the appliance is intended to be installed on a floor without fireproof properties, a fireproof substrate must be placed between the appliance and the floor, in dimensions specified by local regulations.
4. For optimal operation of the appliance and to prevent the risk of fire, the chimney must be cleaned regularly.
5. Ashes must be removed regularly. Dispose of in a fireproof container.
6. Do not operate the appliance if you notice gas emissions.
7. Do not place flammable materials near the appliance.
8. Suitable fire extinguishers should be available in close proximity to extinguish a fire in the appliance in a dangerous situation.

Fire extinguishing instructions

If you notice a fire in your fireplace or chimney, IMMEDIATELY perform the following steps, where they can be performed safely:

1. Close the appliance door.
2. Close the primary combustion air inlet regulator – move it to the left to the closed position.
3. Close the flue gas flow regulator – push it to the closed position.
4. Use appropriate fire extinguishers to extinguish the fire.
5. Call the FIRE DEPARTMENT immediately (telephone for Greece: 199)

Avoid extinguishing the fire using water.

The use of water will likely result in cracking/warping of the metal surfaces of the stove due to the sudden change in temperature. However, **if no other extinguishing agent is available, use water.**

ATTENTION!

After successfully extinguishing the fire, contact a qualified person to check the fireplace and chimney to verify that the device is still suitable for use.

1.8 Use and terms of use

Use refers to the purposes for which the fireplace is designed and approved to operate. Solid fuel fireplaces are used for heating indoor spaces. It is important for the user to be aware of the declared uses of the fireplace, as exceeding these uses can lead to performance problems, overheating or even dangerous situations.

Terms of use refer to the limitations and instructions that the user must follow for the safe and efficient operation of the fireplace. These terms include operating conditions (e.g. temperatures, fuel types, ventilation), limited or inappropriate uses (e.g. prohibition of the use of non-approved fuels), as well as maintenance and inspection requirements.

It is important to note that violating these conditions may lead to damage to the fireplace, poor performance, and risks to the health and safety of users (e.g. carbon monoxide emission or fire).

2. Transport

2.1 Potential risks during transportation

Risks include injuries due to accidents or falling products, damage to packaging, and damage to products. Workers or users moving the product are also at risk if proper transportation methods are not used.

2.2 Proper packaging methods

To ensure safety during transport, the product must be properly packaged in materials that will protect it from shocks and abrasions. It is recommended to use stable wooden or plastic pallets and protective plastic or foam materials.

2.3 Precautions during installation and transportation to high altitudes

Safe handling instructions during transport, such as the use of lifting machinery or equipment, to avoid injury or damage to the products.

2.4 Hazard marking and warnings

Marking with signs warning of the need for caution, indicating the nature of the hazards (e.g., "Heavy product", "Fragile", "Risk of injury").

3. Installation

The manufacturer's liability is limited to the supply of the fireplace.

The installation of the natural flow fireplace with a boiler, including its connection to the central heating system, must be carried out in accordance with applicable national legislation and regulations.

The installation must comply with the rules of the art, be carried out taking into account the instructions & restrictions of this Technical Manual and be carried out by specialized personnel holding the required permits.

The company that undertakes the installation of the natural flow fireplace is responsible for delivering it in a suitable position so that it is ready for use. This includes its parameterization as well as the final checks and tests to verify the safe operation of the entire assembly (fireplace).

The implementation of national and local legislative provisions (e.g. G.O.K., Fire Protection Regulation, etc.) must be constantly ensured.

General steps to be taken before installing and operating the device:

- 1) Make sure that the floor where the appliance is to be installed can and does withstand the load it is to receive (the appliance's own weight, the weight of water, the weight of the lining, the weight of the fuel load, etc.) as well as that it has fire-resistant properties. Otherwise, appropriate measures should be taken to strengthen its strength and cover it with fire-resistant material.
- 2) Make sure that sufficient ventilation is ensured in the area where the appliance will be installed and that the air intended for combustion enters directly from the outside environment (e.g. with a suitable air inlet).
- 3) Avoid installing the appliance in an area where central ventilation ducts, hoods, type B gas appliances, heat pumps or generally devices that can cause negative pressure when operating simultaneously with the stove are in operation.
- 4) Make sure that the chimney and the pipes connecting the stove to the chimney are suitable. Verify that the chimney will be used exclusively and only for connecting your appliance.
- 5) Maintain the minimum free distances (see DECLARATION OF PERFORMANCE or APPLIANCE LABEL) between the sides (sides and rear) of the appliance and adjacent surfaces (e.g. walls, partitions, etc.) when these surfaces are made of flammable materials, under the necessary condition of interposing insulating material 30mm thick and with a thermal conductivity of at least 0.04W/mK or an improved value. For distances shorter than the declared values, the surface of the walls must be covered with a suitable non-combustible material.
- 6) Make sure that the competent person who installed the appliance has checked the secure connection to the chimney and the sufficient inflow of combustion air.

Put the appliance into test operation for (from) two to (up to) three days. Only after it has been verified that it is operating properly, that a secure connection to the chimney has been made and that there are no exhaust emissions in the room, can the decorative lining be installed.

3.1 Potential risks during installation

Risks include accidents due to improper placement, gas or smoke emissions during installation, as well as risks from contact with hazardous materials or overloading the space.

Warning:



Entrust the installation of the device to a specially trained technician.

Professional Installation: The installation of solid fuel fireplaces must be carried out by a certified technician or professional who meets the applicable technical specifications and safety regulations. The technician must ensure that the fireplace is placed in a safe location, away from flammable materials and in an area with adequate ventilation.

Fire prevention measures

The following standard measures must be taken into account to avoid a fire:

1. The appliance must not be operated with the combustion chamber door open.
2. There must be no flammable or heat-sensitive objects or materials within a distance of less than 100cm in front of the hearth.
3. The specified safety distances must be maintained at all times. Within these safety distances from the appliance, no flammable objects must be placed.
4. If the appliance is intended to be installed on a floor without fireproof properties, a fireproof substrate must be placed between the appliance and the floor, in dimensions specified by local regulations.
5. For optimal operation of the appliance and to prevent the risk of fire, the chimney must be cleaned regularly.
6. Ashes must be removed regularly. Dispose of in a container with fireproof properties.
7. You should not operate the appliance if you notice gas emissions.
8. You should not place flammable materials near the appliance.
9. Suitable fire extinguishers should be available in close proximity to extinguish a fire in the appliance in a dangerous situation.

3.2 Installation instructions

The installation of the device must comply with all local regulations in force including those referring to national and European standards.

Combustion air intake duct installation

At the installation location of the device, oxygen must be supplied to start and maintain the combustion of the wood logs, directly from the external environment and not indirectly from the space where the device is installed. This is achieved by installing a suitable air intake.

The opening of the intake that communicates with the external environment must be covered with a suitable shutter that, on the one hand, allows air to be supplied and, on the other hand, prevents the entry of birds, rodents or other animals.

The air intake must be positioned so that it cannot be covered and is protected by suitable shutters.

Where the outlet cannot communicate directly with the external environment, it may communicate with adjacent spaces provided that these adjacent spaces are not used as garages, kitchens, toilets, engine rooms and boiler rooms.

Installation of a flue gas extraction duct

The flue that will be used to connect the appliance to the chimney must be suitable for this use (meet the technical specifications of Regulation 305/2011 and the relevant national provisions) and bear the required certification.

The flue must not have a slope greater than 45° (with respect to the vertical axis) and must be connected to the chimney in a completely airtight manner.

The flue is connected to the top of the appliance at the central outlet of circular cross-section.

During the connection, appropriate fire-resistant material must be used and the necessary tightness must be ensured.

The flue must be properly insulated and must not come into contact with flammable materials.

ATTENTION!

If the flue is not connected to the appliance with absolute tightness, then the release of dangerous gases from the combustion of the wooden logs (e.g. CO, CO₂) and/or a fire may occur.

Installation of a natural flow (expansion) hot air exhaust louver

The area around the appliance, within the decorative fireplace surround, must be constantly and adequately ventilated.

Ventilation helps prevent the appliance from overheating, while the heated air is naturally distributed throughout the interior through the exhaust vent that must be placed on the ceiling of the decorative fireplace surround.

Hydraulic installation

All equipment intended to be installed and to cooperate with the appliance as a single unit of the central heating system, must be suitable for this use in accordance with the instructions of its manufacturers and comply with the technical specifications of the relevant EU Directives & Regulations and the relevant national provisions. Where required, the cooperating equipment must bear the marking or other appropriate marking based on the relevant applicable legislation.

ATTENTION!

In any case, the required safety valves must be installed according to the installation study, which must precede, and the instructions of the licensed installation workshop.

ATTENTION!

Installation should only be carried out by licensed installation crews in accordance with applicable legislation & regulations.

It is PROHIBITED to use the device without installing the safety elements (e.g. overpressure safety valve, thermostatic safety valve, expansion tank, UPS uninterruptible power supply system, etc.) and in a manner other than that specified in the relevant installation study.

ATTENTION!

Before commissioning, the correct operation of all safety elements must be verified by the competent installation workshop.

ATTENTION!

Regular checks of proper operation and maintenance of the system and safety elements must be ensured in accordance with the specifications in the installation design, the instructions of the manufacturers of the individual components and the instructions of the competent installer.

ATTENTION!

In any case, sufficient tightness of the system must be ensured at each connection point, in order to prevent leaks.

ATTENTION!

Care should be taken to install a radiator or hot water cylinder (heat sink), in parallel with the circulation system, which will operate with natural water circulation, to eliminate heat and protect the system in the event of a power outage and circulation pump failure.

It is recommended to install a backup contact thermostat with a built-in battery and an audible signal (buzzer) at the outlet of the fireplace and adjust it to the safety temperature based on the installation study, so that there is an audible indication (warning) in the event of an increase in temperature.

The automatic filling mechanism should be correctly adjusted and the central filling valve should be permanently open so that any water loss is immediately replenished. It is recommended that the water filling system be connected to a tank and not directly to the network, in order to achieve greater safety in the event of interruptions or leaks.

It is recommended to avoid the use of valves at the inlet and outlet of the circulation pump. Where this is not possible, the valves should be able to be locked in their open position.

It is recommended to use a special antifreeze - anti-corrosion liquid in the circuit water to protect the installation components and reduce wear on the circulator. It is **PROHIBITED** to use PARAFLU type liquids & other antifreeze liquids for vehicles since they have anti-thermal properties and prevent the operation of the device. Only the use of a special antifreeze - anti-corrosion liquid for fireplaces is allowed.

It is recommended to install a thermomanometer inside the house, in a space or spaces where the pressure and temperature can be easily monitored by the user.

It is recommended to use a float switch placed in the open expansion tank, which is located at the bottom of the tank (dry Run) and in case of low level, a buzzer and/or a warning light is activated.

Installation of decorative fireplace surround

The material used to make the decorative lining must be suitable (sufficiently fire-resistant) for the high temperatures expected to develop inside the lining.

It is **FORBIDDEN** for the decorative lining of the fireplace to be supported on the hearth. The support must be ensured by an independent metal frame, which will spread the load directly to the ground and not through the hearth.

FIREPLACE CHIMNEY

Design & traction requirements

Before installing the appliance, make sure that the chimney meets the following requirements:

- 1) Its construction ensures its resistance to high temperature, combustion products and possible condensate.
- 2) It is insulated and watertight.
- 3) It is vertical and does not show a reduction in the internal cross-section at any point.
- 4) If there is a change in direction, this does not exceed 45°.
- 5) Its construction must meet any technical specifications of the European Union Directives and the relevant national provisions..

Chimney end

Chimneys installed outside the building must have adequate insulation along their entire length.

It is **PROHIBITED** to connect two or more appliances to one chimney. It is **PROHIBITED** to pass air supply ducts through the interior of the chimney.

The chimney must protrude from the highest point of the roof by at least 1m.

Around the head and within a radius of 10 meters, there must be no obstacles such as walls, slopes and trees. If this is not possible, then the head must be raised at least one meter above the obstacle.

In the event that there are side chimneys, the end of one must be at least 50cm higher than the other, in order to avoid pressure transfer between them.

4. Tips for proper operation

The fireplace is not a household waste incineration unit. Anyone who uses it to burn household waste, chemically treated wood residues, old paper, pollutes the environment and may be prosecuted.

The fireplace is not suitable for burning liquid fuels.

In addition to uncontrolled air pollution and the emission of harmful pollutants, burning unsuitable fuels has a negative effect on the operation and lifespan of the fireplace and chimney.

Burning unsuitable fuels can also cause a fire in the chimney and in the house.

Acceptable fuels

Only dry wood logs with a moisture content of approximately 8%, with a length of approximately 30cm and a maximum circumference of 30cm are permitted to be burned. Smaller pieces of wood can be used for kindling.

Compressed pieces of wood without resin are permitted to be burned. These should be used with particular care. This type of fuel has a high calorific value and if used in large quantities, the device may overheat.

It is dangerous and PROHIBITED to use as fuel: charcoal, paper, pieces of bark and panels, green or painted wood and plastic materials. In the event of damage to the device caused by the use of non-permitted fuels, the manufacturer is not responsible. The warranty provided with the purchase of the device is void in these cases.

The use of paper and cardboard is only permitted as kindling.

Attention!

Paper and cardboard with printed materials on their surfaces are dangerous as when burned, dangerous chemicals contained in the ink are released.

NOTE!

It must be taken into account that it is not possible to continuously heat the space from the fireplace during the night without regular fuel supply.

5. Handling means

5.1 Adjusting the incoming combustion air flow

The device located in the middle, under the flame door, regulates the flow of intake air.

The intake air enters the combustion chamber, under the combustion bed through the lower grate.

It is recommended that when lighting the fireplace, the device be placed in its fully open position (ON) in order to ensure the inflow of a large amount of combustion air.

During combustion and depending on the heating needs of the space, the device can be moved from its fully open position (ON) to its fully closed position (OFF) and/or vice versa, regulating (increasing or decreasing respectively) the amount of air entering the combustion chamber and, by extension, the intensity of the combustion of the wooden logs.

During normal operation of the fireplace, this lever should not be in its fully closed position (OFF), in order to achieve a constant flow of air to maintain combustion.

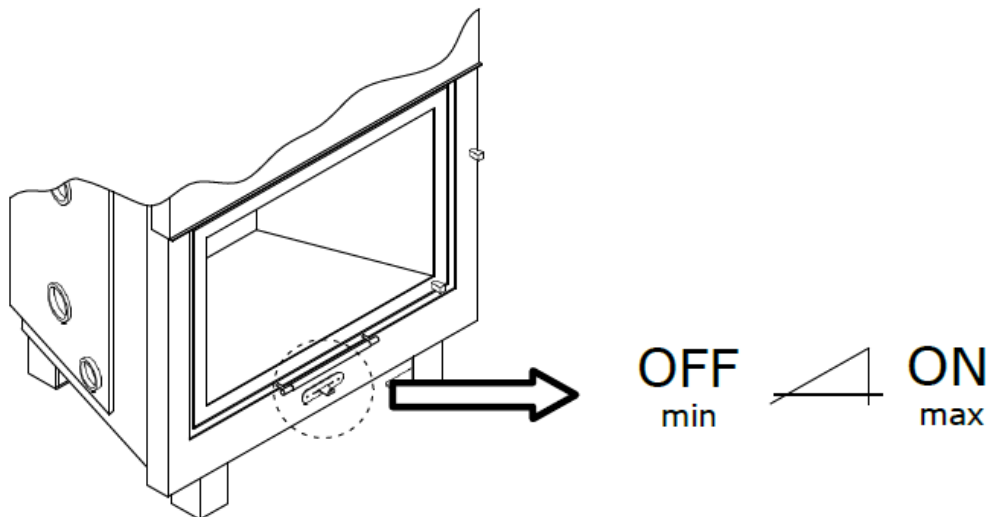

5.2 Flue gas flow adjustment

The lever regulates the flow of flue gases exiting the mouth. During combustion and depending on the heating needs of the space, the lever can be moved from its fully open position (ON) to its fully closed position (OFF) and/or vice versa, respectively increasing or decreasing the rate of escape of flue gases towards the flue and the chimney afterwards.

The adjustment position of the lever affects the residence time of the hot flue gases inside the hearth for a longer or shorter period of time respectively. Thus, the air in the air chambers of the hearth is heated more or less before its exit into the building through the air ducts with the louvers.

The flue gas flow adjustment device is constructed in such a way that even when the relevant lever is in its fully closed position (OFF), the flue gases are allowed to escape through the chimney, ensuring in any case that the combustion chamber will not be filled with smoke.

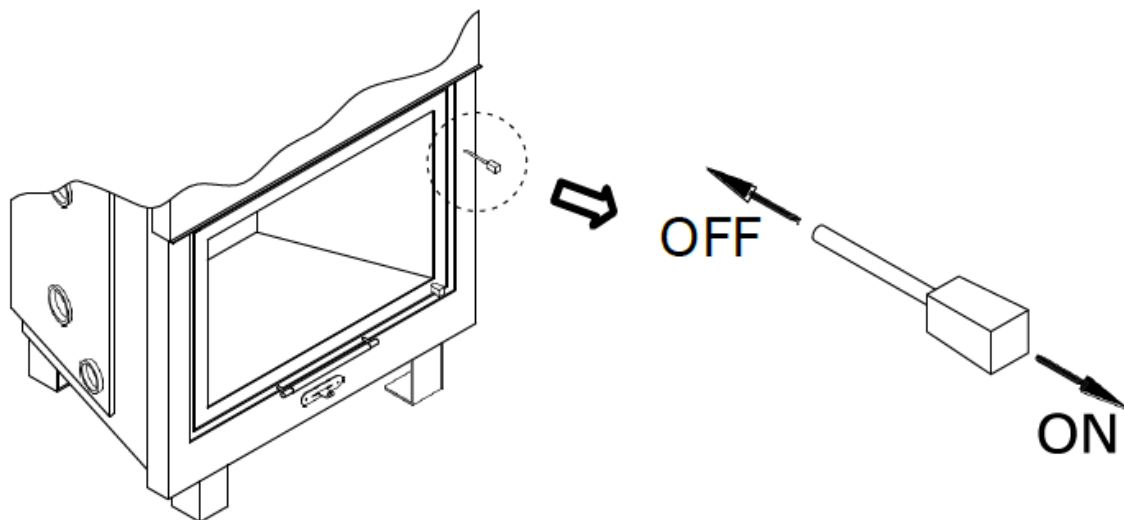

6. Device operation

6.1 Turning on the device

During the first uses of the device, a characteristic odor may develop due to the drying of the device's paint and its sealing adhesive. After a short use, no odor will be noticeable.

The area where the device is used must be adequately ventilated. Never light the device when there are flammable gases in the room.

During the first uses of the device, a limited amount of fuel (wooden logs) should be used in order to give the device the necessary room to expand smoothly due to the increase in temperature.

Only the type of fuel stated in this Technical Manual (see Chapter 7) should be used.

The use of accelerants (alcohol, gasoline, oil, etc.) to light the device is **PROHIBITED**.

When the kindling is lit, place wooden logs (suitable fuel), close the door and adjust the combustion according to the instructions.

For the correct and problem-free operation of the device, the user must observe the following:

1. Ensure adequate ventilation of the room throughout the entire operation of the device.
2. Operate the device during the first ignitions (3 ~ 4 times) with a reduced amount of fuel for a sufficient period of time (6 ~ 10 hours) and adjust the exhaust gas discharge to the "ON" position (fully open) as described in Chapter 8.
3. In subsequent ignitions, gradually larger amounts of fuel are used, until the device operates at maximum load. During this phase, long periods of ignition and shutdown should be maintained as much as possible so that the device can adapt smoothly.

The above steps must be completed before the decorative lining of the fireplace is installed, so that it is possible to check the correct connection of the flue with the fireplace and the chimney. After the above procedure has been successfully completed, the decorative lining can be installed.

When the materials and connections of the decorative lining have dried, the device can operate at normal rates, avoiding excessive loads or the use of fuels that can lead to sudden fluctuations in the temperature of the fireplace surfaces.

When the appliance is used, high temperatures develop which may cause burns to people or animals or cause fire to objects in contact with the appliance or in close proximity.

Safety distances should be maintained for adjacent objects, access restrictions should be taken for children, pets or other animals and contact with its hot surfaces should not be attempted until they have cooled sufficiently.

6.2 Operation under normal conditions

During normal operation of the device, the primary combustion air flow adjustment device can take any position from fully closed to fully open, depending on the heating needs of the space.

ATTENTION!

The device must not be operated with a large amount of fuel or with an excessive inflow of combustion air, as it may overheat and cause damage.

Ash should be regularly removed to allow combustion air to enter the firebox unhindered.

It is PROHIBITED to use the device with the combustion chamber door open because it creates a risk of fire and the emission of dangerous flue gases in the area where it is used..

If you notice a malfunction during operation of the device (e.g. release of flue gases, overheating of the device, etc.), take the following necessary measures:

- Move the primary combustion air adjustment device to the left to the closed position
- Push the flue gas flow adjustment lever to the closed position
- Ventilate the room where the appliance is installed well.
- Do not supply the appliance with additional fuel

If required, apply fire extinguishing measures

In cases of increased ambient temperature (sudden temperature increases), a low degree of chimney draft may occur, even if the device previously operated with a satisfactory degree of draft.

6.3 Extinguishing a fireplace

To reduce or extinguish the fire in the appliance, set the air supply lever to a low level or close it completely. This way, the appliance is not supplied with air, so the fire decreases and gradually goes out. **DO NOT EXTINGUISH THE FIRE WITH WATER!**

Attention:



When wood burns slowly in a closed stove, moisture and tar are produced, which will cause condensation and deposits in the chimney. This can be minimized by burning the stove vigorously for 15 to 20 minutes twice a day.

WARNING:

The fireplace does not emit fumes or smoke into the home if it has been properly installed by a specialist technician, according to the installation instructions, the chimney has been sized correctly and the cleaning and maintenance instructions for the heater are followed.

Occasionally, during ash removal or fuel replenishment, some smoke may be present.

Danger :



Stop using the fireplace if there are fumes or smoke.

In case of smoke emission:

- Open doors and windows to ventilate the area.
- Extinguish the fire and safely remove fuel from the fireplace.
- Check the flue and chimney for any obstructions and clean if necessary.
- Seek the assistance of qualified technicians.
- Do not attempt to operate the fireplace again until the cause of the exhaust emission has been investigated and corrected.

6.4 Operation during the transition period

When the external ambient temperature is above 140C, combustion disturbances may occur and the chimney draft may be reduced and the flue gas may not be completely evacuated.

Carefully remove the ash to enhance air circulation under the fireplace.

6.5. Feedback

To refuel the device with recommended fuel, follow the steps below:

1. Open the flame door.
2. Supply fuel to the combustion chamber.
3. Close the flame door and secure it.
4. Repeat the process at regular intervals for as long as you wish to keep the device running.

7. Maintenance

7.1 Potential hazards during maintenance

Hazards from residual heat, handling exhaust gases or contact with hot surfaces.

7.2 Protective measures during maintenance

Use of gloves, face masks and other protective equipment during cleaning and maintenance of fireplaces.

7.3 Cleaning and maintenance

It is important that the fireplace is maintained regularly and in accordance with these instructions. Maintenance should be carried out at least once a year by a qualified technician.

Danger :



The fireplace should be cleaned when it is completely cold.

Chimney cleaning

Cleaning must be entrusted to a competent person and is necessary to remove the soot that accumulates in the chimney.

Otherwise, the appliance may malfunction and/or cause a fire. During cleaning, the appliance and the chimney must be sufficiently cooled.

Cleaning must be carried out regularly, at least once a year and/or at shorter intervals depending on use.

To limit soot inside the combustion chamber during the chimney cleaning process, the ashtray should be in place and the hearth door should be kept in its closed position.

Cleaning ceramic glass

ATTENTION!

The crystal should be cleaned after it has cooled to room temperature. Otherwise, it may crack and/or cause burns.

The frequency of crystal cleaning depends on:

- ✓ the quality of the fuel used and the moisture content,
- ✓ the settings selected when using the device and
- ✓ the frequency of use of the device.

To clean the crystal, follow the steps below:

1. Lower the door to its closed position.
2. Rotate the lever located on the right side of the door frame. To unlock, rotate counterclockwise $\frac{1}{4}$ of a full turn
3. Once unlocked, pull the lever toward you to open the door. The door will swing to the left and the glass will be fully exposed toward you for easier cleaning.
4. Once you have finished cleaning the glass, close the door and lock it by rotating the lever clockwise.
5. Before lifting the door, make sure it is properly locked. Do not lift it if the door is wobbling, as this could cause the glass to crack.

ATTENTION!

To remove soot, you can use special cleaning products for ceramic crystals and absorbent paper. If stains have formed that require rubbing to remove, you can use a special scraper for ceramic crystals, taking special care to avoid scratching the crystal.

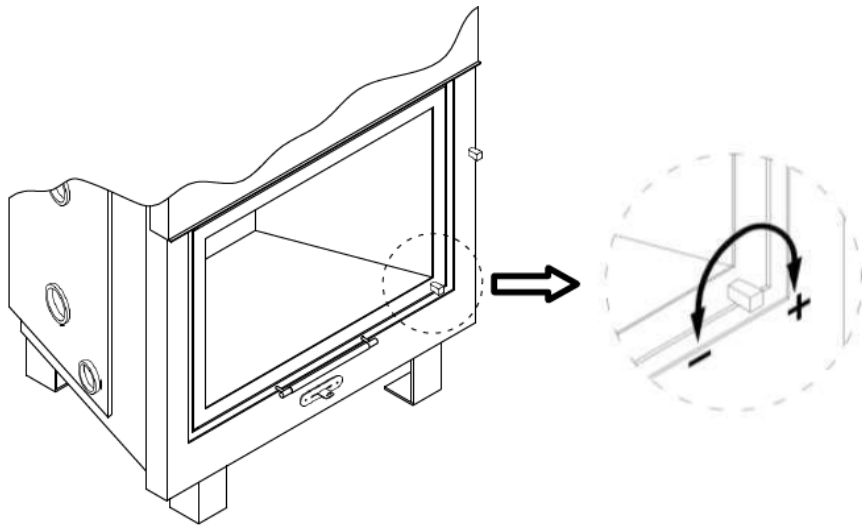

To clean the glass, do not use cloths that may scratch the surface or products (e.g. chemicals) that are not suitable for ceramic glass as they may cause the glass to fog up.

DO NOT operate the appliance if the door is not properly secured. In this case, the combustion chamber is not adequately insulated and the appliance cannot operate properly, and flue gases may leak into the installation area..

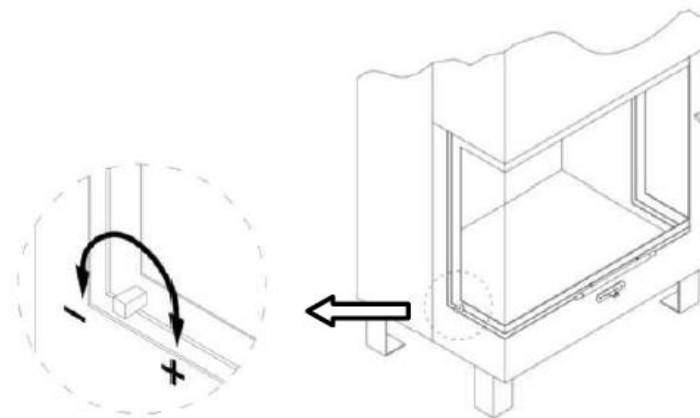

NOTE!

The glass is made of ceramic materials that can withstand temperatures up to 7500C without creating any irregularities. Cracks may occur during cleaning if the following rules are not followed or due to mechanical causes due to misuse of the appliance (impacts with objects, violent opening or closing of the door, etc.). The warranty does not cover the replacement of the glass, as it cannot be damaged during the appropriate operation of the appliance in accordance with the instructions and limitations of this Technical Manual.

Cleaning the fireplace from ash

ATTENTION!

The temperature that the ashtray develops when the stove is operating and for a certain period of time after it has stopped is extremely high.

Ash must be removed from the ashtray regularly.

The appliance must not be operated when the ashtray is completely full as it makes it difficult for air to pass through and causes the grate to overheat.

The ashtray is equipped with a handle that allows it to be handled with a “bare hand” only if the appliance has stopped operating and all its parts, including the ashtray, have cooled sufficiently. Otherwise, the special glove that comes with the appliance should be used.

To clean the ash, follow the steps below:

1. Use a small broom to collect the ash in the ashtray.

2. Lift the grate located at the base of the fireplace.
3. Remove the ashtray located under the grate.
4. Discard the ash (it is recommended to use a special fireplace ash cleaning broom). Before discarding the ash, make sure that the ash has cooled completely and is at room temperature. Otherwise, a fire may occur in the container or the area where it is to be discarded.
5. Replace the empty ashtray in its original position.
6. Replace the grate in its original position.

Door sliding guide maintenance

The vertical movement of the door is done with the help of metal guides on which it slides, ensuring silent operation.

To maintain the correct and silent operation of the door, the lubricant must be renewed regularly. The lubricant must be suitable for the device. To lubricate the guides, follow the steps below:

1. Lift the door until it is fully open.
2. Locate the slide guides and apply the lubricant according to the manufacturer's instructions.
3. Lower and raise the door several times so that the lubricant spreads along the guides.
4. If the door still moves with difficulty or there is noise during operation, repeat the procedure..

ATTENTION!

Do not apply a large amount of lubricant to avoid the possibility of lubricant leaking onto the hob. Prefer most repetitions by applying a small amount of lubricant.

Not using the fireplace during the summer months

During the summer, make sure the heater is cleaned and the moving parts are lubricated.

Leave the air intake lever slightly open so that air can enter through the fireplace into the flue, thus preventing moisture and condensation in the chimney.

Fireplace not in use for an extended period of time

IMPORTANT: If the fireplace is not going to be used for a while, clean it carefully and leave the air control slightly open to allow air to circulate. Make sure that rainwater cannot enter the flue. Install a chimney cap, which should not completely block the flue.

These measures should ensure that there is a slight movement of air through the fireplace, and that the body of the fireplace remains dry, as well as its corners.

Ash left in a fireplace when it is not in use can absorb moisture like blotting paper. If moisture settles inside the fireplace, rust forms. The more rust settles, the more it expands. This can put excessive pressure on the joints of the fireplace, resulting in damage.

NOTE: It is recommended that you clean your fireplace thoroughly after each use. Adding a dehumidifier to the combustion chamber, such as cat litter, helps absorb moisture during the summer months. Be sure to remove it before the start of the use season.

8. Removal, disassembly and demolition

Αποσυναρμολόγηση

If the fireplace needs to be dismantled, it is recommended that it be carried out by a professional to avoid risks associated with improper dismantling of the burner or chimney. The flue pipes and other parts must be dismantled carefully.

Demolition

In the event of demolition of the fireplace, local regulations for the removal and recycling of materials must be followed. Many parts of the fireplace, such as metals and refractory materials, can be recycled.

8.1 Potential risks

During decommissioning, the main risks include damage to connection systems, the ejection of smoke or dust, and the falling of large or heavy components.

8.2 Protective measures during uninstallation

Use of protective equipment (such as gloves and safety glasses) during the procedure.

8.3 Materials and Tools Required for Uninstallation

Tools for disassembly (e.g., wrenches, hammers) and methods for safely removing fireplace or heater components.

8.4 Potential risks during deconstruction and demolition

Risks include waste management, destruction of building materials, and the release of hazardous particles or gases.

9. Information in case of damage or danger

9.1 Generally

Fault Identification

- **Low Efficiency Fireplace Lit:** If the fireplace is not heating sufficiently, it may mean that the chimney is blocked or that combustion is not complete due to unsuitable fuel or overloading.
- **Smoke or Exhaust Gas Leakage:** If smoke or exhaust gas leakage is observed inside the room, the use of the fireplace must be stopped immediately and the chimney and door seals must be checked.
- **Temperature Higher Than Normal:** Overheating can be caused by poor ventilation or poor system maintenance.

Repair Process

- **Contact a Professional:** In the event of a fireplace malfunction, you must contact the manufacturer or a qualified technician to have the product checked and repaired. Do not attempt to repair the fireplace yourself, as this may worsen the malfunction or cause additional hazards.

Component Replacement: If any element of the fireplace (such as the chimney or door) is damaged, it must be replaced immediately to ensure its safe operation.

9.2 In case of a chimney fire

The chimney can catch fire if improper or liquid fuels are used.

If you notice a fire in your fireplace or chimney, IMMEDIATELY perform the following steps, where it is safe to do so:

- 1) Close the appliance door.
- 2) Close the primary combustion air inlet regulator – move it to the left to the closed position.
- 3) Close the flue gas flow regulator – push it to the closed position.
- 4) Use appropriate fire extinguishers to extinguish the fire.
- 5) Call the FIRE DEPARTMENT immediately (telephone for Greece: 199).

Warning:



Do not pour water on the fire!!! You will not put out the fire and cracks will probably develop due to the sudden change in temperature.

The use of water will likely result in cracking/warping of the metal surfaces of the stove due to the sudden change in temperature. However, if no other extinguishing agent is available, use water.

ATTENTION!

After successfully extinguishing the fire, contact a qualified person to check the fireplace and chimney to verify that the device is still suitable for use.

9.3 In case of power outage

ATTENTION: In the event of a power outage and when the motor is not working, there is a risk of damage to the electrical parts of the hob (thermostat - cables, etc.). In this case:

- ✓ Let the stove go out and do not add wood.
- ✓ Close the primary and secondary air supply to reduce the intensity of the flame.
- ✓ Open the lower door that covers the thermostat to improve ventilation around it..

If the user of the device does not take the above actions, it is certain that the thermostat will be damaged due to overheating.

9.4 Possible faults and causes

DAMAGE	CAUSE	SOLUTION
The fire is not burning properly and the space is not heated.	The wood has moisture.	Check the wood. The moisture content should be <20%.
	Wrong fuel.	Use the appropriate woods.
	The chimney is not "pulling" well.	Check that the flue gas discharge lever is open. Close any open doors of other appliances connected to the chimney. Close the cleaning openings. If necessary, clean the flue.
	Insufficient combustion air.	Check the air supply and open the air intake and adjustment lever. Open the fan or window. Clean the ash from the hearth.
Smoke nuisance.	Insufficient combustion air.	Check the air supply and open the air intake and adjustment lever Open the fan or window. Clean the ash from the hearth.
	Unused fuel.	Do not add additional wood when the fire has an orange flame.
Fire in the chimney.	Wrong fuel. Overloading with wood. Inadequate maintenance.	Close the air intakes and call the fire department immediately.
Το τζάμι λερώνεται πολύ γρήγορα.	The wood has moisture.	Check the wood. The moisture content should be <20%.
	Wrong fuel.	The size of the wood is quite large. Use the appropriate wood.
	Excessive fuel.	Do not use more than 2 to 3 sticks at the same time.
	Insufficient combustion air.	Check the air supply and open the air intake and adjustment lever Open the fan or window. Clean the ash from the hearth.

10. Warranty



MISAILIDI FOUNDRY WARRANTY

✓ Warranty 2 years from date of purchase.

The warranty ceases to be valid if:

- The product was used for a use other than that for which it was intended.
- Damage was caused by accidents, incorrect use, maintenance, etc.
- An attempt was made to use it by third parties and generally unauthorized persons, without the manufacturer's approval.
- The product was installed, maintained, used or stored in a manner other than that recommended in the instruction manual that accompanies it.
- Parts were used for a given construction of a different origin than that of the manufacturing plant.

The warranty does not include the ceramic crystals.

THE MANUFACTURER