



FOUNDRY: 7,5° Km THESSALONIKI-KAVALA  
FACTORY: PERIVOLAKI LAGADA  
T. 0030 23940 20799, 0030 2310 688988  
F. 0030 2310 681033  
[www.tzaki.com.gr](http://www.tzaki.com.gr)

# **USER MANUAL OF ENERGY APPLIANCES ECO TYPE**

EDITION: MARCH 2021

The CE mark is a large, bold, black symbol consisting of the letters 'C' and 'E' joined together, indicating conformity with European standards. It is positioned on a light blue, geometric background that resembles a stylized building or a series of overlapping planes.

## CONTENTS

1. Introduction
2. General Information
  - 2.1. Description – appropriate use
  - 2.2. Technical features
3. Installation
  - 3.1. General
  - 3.2. Installation of combustion air intake air duct
  - 3.3. Installation of the flue gas exhaust
  - 3.4. Installation of hot air exhaust vents (expansion)
  - 3.5. Installation of decoration of the fireplace
4. Chimney
  - 4.1. Requirements for the construction and draft
  - 4.2. Flue terminals
5. Safety regulations
6. Fire hazard
  - 6.1. Measures to prevent fire
  - 6.2. Fire extinguishing instructions
7. Combustible material for use in the appliance
8. Operating mode
  - 8.1. Set incoming flow of the combustion air
  - 8.2. Set exhaust flow
9. Ignition of the appliance
10. Feedback
11. Operation in normal conditions
12. Operation in conditions of increased ambient temperature
13. Maintenance instructions
  - 13.1. Chimney cleaning
  - 13.2. Cleaning of the ceramic glass
  - 13.3. Cleaning the appliance from the ashes
  - 13.4. Maintenance of the door sliding guides
14. Handling during the summer
15. Declaration of performance
16. Technical fiche

## **1. INTRODUCTION**

The energy fireplaces **ECO TYPE** are constructed in accordance with the Regulation 305/2011 of the European Union, "on the establishment of harmonized conditions for the marketing of construction products" and the EN 13229 Standard and bears the **CE** mark.

Representative samples of the **ECO TYPE** energy fireplaces have been tested by an accredited laboratory of the European Union as to the requirements of EN 13229, EN 13229/A1, EN 13229/A2 while through the certified Quality Management System according to ISO 9001, is documented that the manufacturing process ensures the compliance of the manufactured products, allowing the affixing of the marking **CE**.

Each outlet of the natural flow of the group bears the CE marking in a visible place as required by the legislation in force that allows free movement within the Member States of the European Union, only the products that have been tested, certified and bear the **CE** marking.

This manual was written for your safety and the safety of others. You ought to read, to understand and obey what is specified in it, along with any specific national and European regulations, to consult for any action on the use of the product and keep it with care, bearing in mind that you may need to consult it in the future.

Before installing the fireplace, the installer should be aware about the requirements - guidelines - restrictions of this manual.

Prior each operation of the appliance, the operator must be aware about the requirements - guidelines - restrictions of this manual. Only with full knowledge of this manual can avoid mistakes and ensure the smooth operation of the product.

Please read carefully this manual before using the product.

The manufacturer does not accept the responsibility for the operation of the energy appliance of **ECO TYPE** beyond its intended use and for cases where the conditions - requirements specified in this Technical Manual are not met.

## **2. GENERAL INFORMATION**

### **2.1 Description – appropriate use**

This technical manual refers to the energy fireplaces **ECO TYPE**.

The appliances have an inlet air control lever (primary air), the operation of which is described in §8.1. At the same time, depends on the appliance, in the back of the flame chamber as well as in the frame of the flame door, there are holes for the flow of the secondary and tertiary combustion air respectively.

The ceramic glass of the door is durable up to 750°C allowing visual contact with the combustion chamber without the need to open the door.

The appliance is used exclusively for heating the interior of buildings (except bedrooms) that meet the provisions of local construction regulations and other relevant provisions.

The energy appliances **ECO TYPE** are characterized as intermittent appliances.

The **ECO TYPE** fireplace consists of the following main parts:

- Combustion chamber made of steel
- 1 or 2 (depends on the appliance) fire doors with ceramic crystal.
- Sliding door mechanism with sliding guides and counterweight.
- Fixed flue gas deflector inside the flame chamber.
- Primary air inlet control (see 8.1).
- Air inlet provision, mounted on the back of the flame chamber (depends on the appliance).

- Air inlet provision, mounted in the frame of the flame door (depends on the appliance).
- Flue damper control.
- Ash Pan.

Also, the appliance can work with pipelines for:

- The entrance of the primary combustion air from the outside surroundings and
- The exit of the flue gases from the combustion chamber to the outside surroundings.

**This appliance is not suitable for use by persons (including children) with reduced physical, sensory or mental capabilities or lack of experience, unless they are supervised and instructed by individuals responsible for their safety.**

**ATTENTION!**

**Any modification of the appliance is not allowed.**

**WARNING!**

**Inform the children that the appliance acquires a high temperature and should avoid contact with all of its surfaces.**

**ATTENTION!**

**The appliance should always work under the supervision of the operator. It is prohibited to operate without supervision.**

## **2.2 Technical features**

Please see the label affixed to the device.

## **3. INSTALLATION**

### **3.1 General**

The responsibility of the manufacturer is limited to the supply of the appliance.

The installation of the energy appliance including the connection with the central heating system should be in accordance with applicable national laws and regulations. The installation must conform to the rules of art, be made by taking into account the guidelines and restrictions of this Technical Manual and conducted by qualified personnel that carry the required licenses.

The company that undertakes the installation of the energy appliance is responsible for the delivery of such a position so as to be ready for use. This includes the parameterization and final examinations and tests to verify the safe operation of all assemblies (fireplace).

It should be always ensured the implementation of the national and local legislation (e.g. General Building Regulation, Standard HD 384, Fire Protection Regulations, etc.)

General steps to be done before installation and operation of the appliance:

- 1) Make sure that the floor where the device is intended to be installed, can and does withstand the load to be received (same weight of the device, weight of decorative plasterboard, fuel weight, etc.) as well as that it has fire-resistant properties. Otherwise, appropriate measures should be taken to enhance its strength and cover it with fire-resistant material.
- 2) Make sure there is adequate ventilation of the area where you will install the appliance and the combustion air enters directly from the external environment (e.g. with a suitable nozzle of inlet air).
- 3) Avoid the installation of the appliance in a place where they operate central ventilation ducts, hoods, gas appliances Type B, heat pumps or general appliances that can cause depression when operated simultaneously with the appliance.
- 4) Make sure for the suitability of the pipelines connecting the appliance to the flue and of the chimney as well as that the chimney will be used exclusively for the connection of your appliance, verify the suitability of the pipeline connecting of the appliance with the central heating system.

- 5) Maintain minimum safety distances (see DECLARATION OF PERFORMANCE or DEVICE LABEL) between the sides (side & back) of the appliance and the side surfaces (e.g., walls, partitions, etc.) when these surfaces are made of flammable materials under the prerequisite interference of 30mm thickness insulator and thermal conductivity of at least 0,04W/mK or better. For shorter distances of 10cm, the side surfaces should be coated with a suitable non-combustible material.
- 6) Ensure that the competent person who installed the appliance has checked the safe connection to the chimney and adequate flow of combustion air.

**Put the appliance into test mode for two to three days. Only if it is determined that it works properly, that it has become a safe connection to the chimney (there is no emission of flue gases in the installation area) and that it has been a safe connection to the central heating system (no leaks from the connection points) trims can be placed.**

### **3.2 Installation of combustion air intake air duct**

At the installation site of the appliance, oxygen must be provided to start and maintain the combustion of the logs, directly from the external environment and not indirectly from the place where the appliance is installed. This can be achieved by placing the appropriate air inlet vent. The opening of the nozzle which communicates with the external environment should be lined with suitable blinds that initially allow the production of sufficient quantities of air and secondly prevents the entry of birds, rodents or other animals.

The diffuser of the air must be positioned so as not to allow coverage and be protected by appropriate blinds. If the nozzle is not possible to communicate directly with the outside environment, is allowed to communicate with adjacent spaces. It is **FORBIDDEN** the combustion air to be from side rooms used as garages, kitchens, toilets, engine and boiler rooms.

### **3.3 Installation of the flue gas exhaust**

The flue pipe that will be used to connect the appliance to the chimney should be appropriate for this use (to meet the technical requirements of the Regulation 305/2011 and relevant national provisions) and bear the required **CE** certification.

The flue pipe must not be steeper than 45 degrees (relative to the vertical axis) and must be connected to the chimney, with a fully sealed manner. The flue pipe is connected to the top of the appliance to the central outlet of circular cross section. At the connection should be used suitable fireproof material and should be ensured the necessary tightness. The flue pipe must be insulated properly and should not come in contact with flammable materials.

**ATTENTION:** In case that the flue pipe is not connected with complete sealing, then the appliance may not function properly and can also be observed release of hazardous gas emissions from combustion of wood logs (e.g. CO, CO<sub>2</sub>) and/ or cause fire.

### **3.4 Installation of hot air exhaust vents (expansion)**

The space around the device, inside the decorative lining of the fireplace, must be constantly and adequately ventilated. Ventilation helps not to overheat the appliance. An expansion blind should be placed on the ceiling of the decorative lining of the fireplace. A second air intake of larger and / or equal dimensions must be placed at the bottom of the decorative cladding of the fireplace. The cold air that will enter from the lower louver will be heated inside the lining and will leave from the upper louver of expansion, creating a hot air flow circuit that will diffuse inside the house with natural flow.

### **3.5 Installation of decoration of the fireplace**

The construction material of the decorative coverings must be suitable for high temperatures that are expected to develop inside the decoration. This material should exhibit refractory properties.

It is **FORBIDDEN** the decorative lining of the fireplace to be based on the appliance. Support should be ensured by independent metallic frame, so that the weight of the decorative liner cannot be transferred to the appliance.

## **4. CHIMNEY**

### **4.1 Requirements for the construction and draft**

Before you place the appliance, make sure that the chimney satisfies the following:

- a) The construction ensures resistance to high temperature combustion products and any condensates.
- b) It is insulated and watertight.
- c) It is vertical and does not show reduction of internal cross at any point.
- d) If there is a change in direction, that does not exceed 45 degrees.
- e) The construction must comply with any technical specifications of the European Directives and relevant national legislation (Reg. 305/2011, etc.).

Chimneys that are installed outside the building must have adequate insulation along their entire length.

**It is FORBIDDEN to connect two or more appliances in one chimney.**

**It is FORBIDDEN to pass air ducts from the interior of the chimney.**

### **4.2 Flue terminals**

The chimney must protrude from the highest point of the roof at least 1m. Perimeter of the head and within a radius of 10 meters, no obstacles should be inserted such as e.g. walls, slopes and trees. If this is not possible, then the head must be raised at least one meter above the obstacle. In case there are side chimneys, the end of one should be at least 50cm higher than the other, in order to avoid the transfer of pressure between them.

## **5. SAFETY REGULATIONS**

The appliance must be operated in accordance with this technical manual. The equipment cooperating with the device must be suitable and have the required certifications (e.g. ) where required by applicable laws & regulations.

All maintenance or repair work should only be performed by qualified technical personnel with the approval of the manufacturer or his representative. Any maintenance or repair work should only be carried out if the appliance has been cooled to ambient temperature.

The spare parts that may be used must have been approved by the manufacturer.

**CAUTION!** The installation & operation of the device in bedrooms should be avoided. Otherwise, an appropriate flue gas leak detection and warning system should be installed.

## **6. FIRE HAZARD**

### **6.1 Measures to prevent fire**

The following typical measures should be taken into account to avoid fire hazard:

- a) The appliance should not be working with the door of the combustion chamber opened.
- b) In front of the fireplace should not be any object or material that is flammable or heat sensitive within a distance of 100cm.
- c) You must always keep the safety distances specified in §3.1. Within these safety distances from the appliance, should not be interfered any other movable flammable objects.
- d) If the appliance is intended to be installed on a floor with no refractory properties, then there should be placed a fireproof material (e.g. steel sheet) between the appliance and the floor, in size that the local regulations define.

- e) For the optimal operation of the appliance and to prevent the risk of ignition of flue gases that are deposited on the walls of the chimney the cleaning of the chimney should be regularly repeated.
- f) The combustion residues (ashes) should be removed regularly. Caution should be exercised in their handling due to high temperature - It is recommended their handling if they have cooled sufficiently. For the temporary storage and to cool them in a safe temperature, the ashes must be collected in a suitable container with refractory properties.
- g) You should not turn on the appliance if there are emissions of gases or fumes.
- h) You should not place inflammable materials near the appliance.
- i) There should be sufficient number of proper fire extinguishers in positions easily accessible and instantly perceived in order to extinguish a fire on the appliance in a hazardous situation. The adequacy of the fire extinguishers should be checked regularly by a competent person in accordance with applicable law.

## **6.2 Fire extinguishing instructions**

If you detect a fire in the fireplace or chimney, **IMMEDIATELY** perform the following steps, where they can be performed safely:

1. If possible, close the door of the combustion chamber good.
2. If possible, move the primary air inlet control to the fully closed position (see Chapter 8).
3. If possible, move the flue damper control to the fully closed position (see Chapter 8).
4. Use **appropriate fire extinguishers** to put out the fire. **Use water to extinguish a fire if there are no available suitable fire extinguishers.**
5. Call the Fire Service.

After successfully extinguishing the fire please contact to qualified person to check the appliance and the chimney for any cracks or points without proper tightness.

### **CAUTION!**

After successfully extinguishing the fire, consult a qualified fire and chimney specialist to verify that the appliance is still suitable for use

## **7. COMBUSTIBLE MATERIAL FOR USE IN THE APPLIANCE**

You may use only dry wood logs with a humidity of about 8% and a length of about 30cm and 30cm maximum circumference. Smaller woods can be used as firelighters.

**You may burn compressed wood parts without resin such as those are commercially available. Using this type of fuel should only be done with particular attention. This type of fuel has a high calorific value and can cause overheating with harmful results if you use large quantities.**

**It is dangerous and it is PROHIBITED to use it as fuel: coals, papers, pieces of bark and panels, green or painted wood and plastic materials. In case the device is damaged by the use of unauthorized fuels, the manufacturer does not bear any responsibility. The warranty provided with the purchase of the device is void in these cases.** Paper and cardboard may only be used as firelighters.

**Caution!** Paper and cardboard that have prints on their surfaces are dangerous as burning those releases dangerous chemicals contained in the ink

**NOTE!** It should be borne in mind that it is not possible to continuously heat the space from the hearth during the night without regular refueling.

The woods that are in the combustion chamber after some time are consumed (burned) and so they do not generate heat.

It is **FORBIDDEN** to use the appliance as an incinerator.

## 8. OPERATING MODE

### 8.1 Set incoming flow of the combustion air

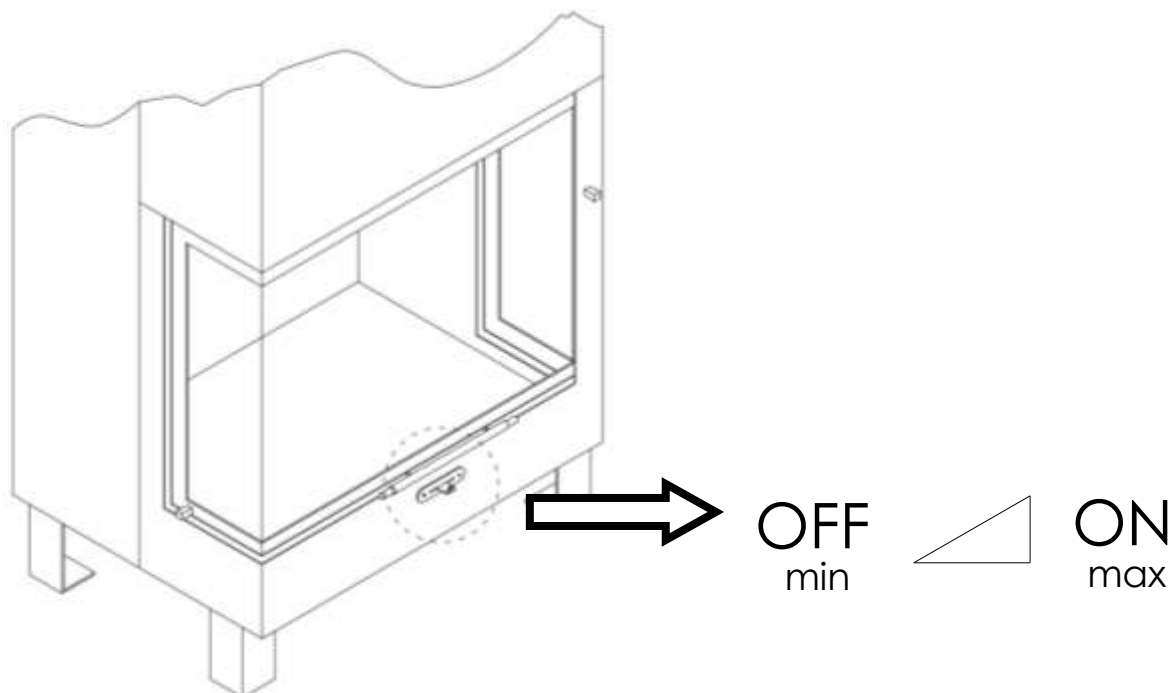

**Figure 1: Typical ECO TYPE appliance primary air inlet control**

The **primary air inlet control** located in the middle, below the fire door, achieves adjustment of the intake air flow. Intake air enters the combustion chamber, below the fire bed through the bottom grate.

After ignition of the appliance, it is recommended the primary air inlet control to be placed in its fully open position (ON) to ensure the inflow of a large amount of combustion air.

During combustion and depending on the space heating needs, the primary air inlet control can be moved from its fully open position (ON) to its fully closed position (OFF) and / or vice versa, adjusting (increasing or decreasing respectively) the amount of the air entering the combustion chamber and consequently the intensity of combustion of the wooden logs.

During normal operation of the appliance, the primary air inlet control must not be retained in its fully closed position (OFF), in order to achieve a continuous flow of air to maintain combustion.

### 8.2 Set exhaust flow

The flue damper control regulates the flow of flue gases coming out of the nozzle. During combustion and depending on the space heating needs, the flue damper control can be moved from its fully open position (ON) to its fully closed position (OFF) and / or vice versa, increasing or decreasing the escape rate of the flue gases to the flue and the chimney then.

The setting position of the flue damper control affects the residence time of the hot flue gases inside the hearth for a longer or shorter period of time respectively.

The flue gas regulating structure is constructed in such a way that even when the flue damper control is in its fully closed position (OFF), the flue gas is allowed to escape through the chimney, ensuring in any case that the combustion chamber will not be filled with smoke.



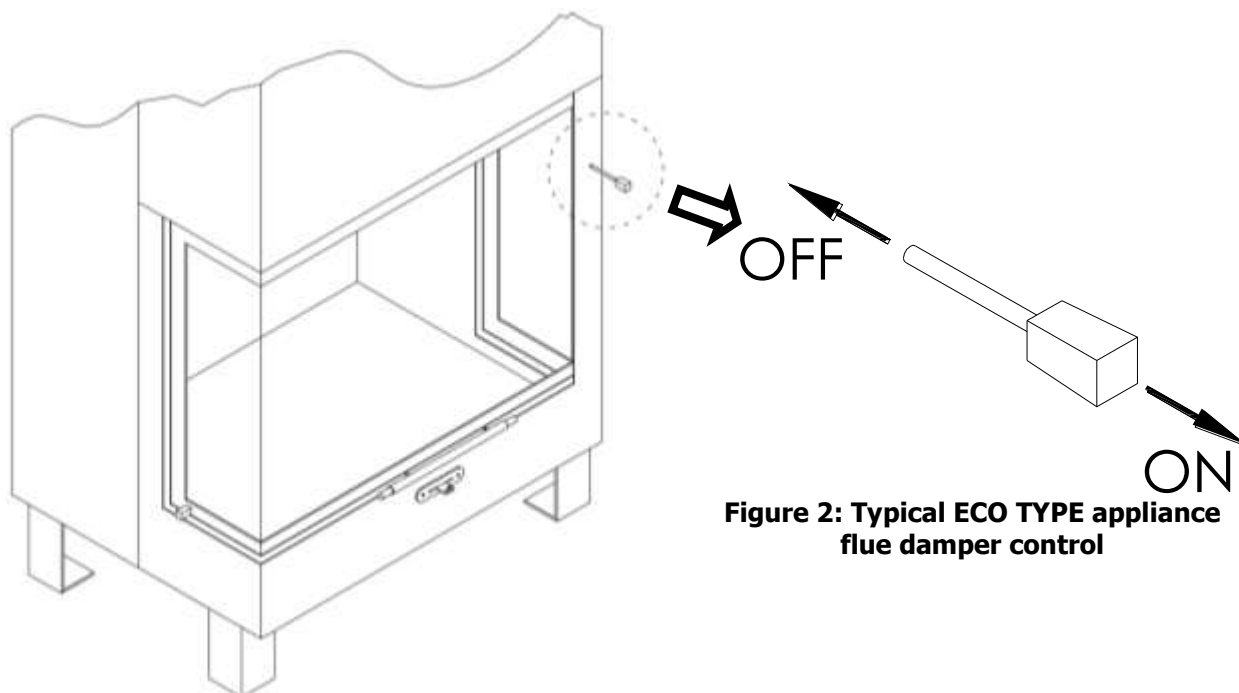

Figure 2: Typical ECO TYPE appliance flue damper control

## 9. IGNITION OF THE APPLIANCE

During the first uses of the device, a characteristic odor may occur due to the drying of the paint of the device and its sealing adhesive. After a short use, no odor will be noticed.

The user area of the appliance must be adequately ventilated. Never switch on the appliance when there are flammable gases in the room.

During the first uses of the device, a limited amount of fuel (wooden logs) should be used in order to give the required margin to the device to expand smoothly due to the increase in temperature.

Only the fuel type stated in this Technical Manual (see Chapter 7) should be used.

It is **PROHIBITED** to use accelerators (alcohol, gasoline, oil, etc.) to light the appliance.

When the lighters come on, install wooden logs (suitable fuel), close the door and adjust the combustion according to the instructions in Chapter 8.

For the correct and trouble-free operation of the device, the user must observe the following:

1. To ensure adequate ventilation of the area throughout the operating duration of the appliance.
2. To operate the appliance in the first lighting (3 ~ 4 times) with reduced amount of fuel for sufficient time (6 ~ 10 hours) and to regulate the export of exhaust gases to position "B" (fully open) as described in Chapter 8.
3. In the next lightings to be used progressively greater quantities of fuel up to the point that the appliance will operate at maximum load. During this phase it should as far as possible be maintained long periods of lighting up and switching off, so that the appliance will adjust smoothly.

The above steps must be completed before placing the decorative covering of the appliance so that at the same time there is the possibility to check the proper connection of the flue with the appliance and chimney. After having successfully completed the above process, decoration can be placed.

When the materials and the connections on the decoration have dried up, the appliance can be operated as normal, avoiding excessive loads or the use of fuels that can lead to sudden fluctuations the temperature of the surfaces of the appliance.

**When the appliance is in use, high temperatures are developed, which can cause burning in humans or animals or cause fire to objects that touch the appliance or are in close distance. It should be kept safe distances for the adjacent objects, to be taken reduction measures of access for the children, pets or other animals and not to attempt contact with hot surfaces until they are cooled sufficiently.**

### 10. FEEDBACK

To feedback the appliance with recommended fuel follow the steps below:

1. Pull up the door from the handle to open.
2. Feed with the recommended fuel the combustion chamber.
3. Close the door of the combustion chamber and make sure it is locked in the closed position so that no fumes are emitted indoor.
4. Repeat the procedure when the fuel in the combustion chamber has been consumed and for as long as you want to keep the appliance burning.

### 11. OPERATION IN NORMAL CONDITIONS

During normal operation of the appliance, the adjustment lever of the air flow for combustion and the regulating lever of the flow of flue gases can take any position from fully closed to the fully open, depending on the needs of space heating.

#### **CAUTION!**

**The appliance should not operate with large amounts of fuel or with excessive inflow of combustion air, because it may overheat and cause damages.**

It should be taken care for regular disposal of ashes (see chapter 13) to allow the primary air for the combustion to circulate in the combustion chamber.

**It is FORBIDDEN to use the appliance with the combustion chamber door open it creates a risk of fire and emission of dangerous fumes (CO, CO<sub>2</sub>) inside the installation area**

If during the operation of the appliance notice impairment (e.g. release fumes, overheating of the appliance etc.) take the following necessary steps:

- Move left the primary air inlet control in the fully closed position (see Figure 1)
- Push the flue damper control to the closed position (see Figure 2).
- Ventilate well the area where the appliance is installed.
- Do not refuel the appliance.

If it is necessary, follow the fire extinguishing measures (see Chapter 6).

### 12. OPERATION IN CONDITIONS OF INCREASED AMBIENT TEMPERATURE

In cases of ambient temperature rise (sudden rise in temperature) there may be a small degree of traction of the chimney, even if the appliance has previously operated with a satisfactory degree of traction.

### 13. MAINTENANCE INSTRUCTIONS

You must follow the safety rules which are specified in Chapter 5.

### 13.1 Chimney cleaning

Cleaning should be entrusted to a competent person and is necessary to remove the soot that accumulates in the chimney. Failure to do so may result in malfunction of the device and/or fire.

The appliance and chimney must be adequately cooled during cleaning. Cleaning should be done regularly, at least once a year and/or at shorter intervals depending on the use.

To reduce the soot inside the flame chamber during the chimney cleaning process, the ashtray should be in place and the hearth door should be kept closed.

### 13.2 Cleaning of the ceramic glass

#### CAUTION!

The ceramic glass must be cleaned after it has been cooled to environment temperature. If you attempt to clean it while it is hot it may crack while there is a risk to burn.

The cleaning frequency of the ceramic crystal depends on:

- The quality of the used fuel and moisture content
- The selected settings when using the appliance and
- The frequency of use of the appliance.

For the cleaning of the ceramic glass, follow the steps below:

1. Move lower the door in closed position.
2. Rotate the **door frame control** located on the bottom side of the door frame. To unlock the door, turn the **door frame control** counterclockwise  $\frac{1}{4}$  of a full rotation
3. Once you unlock the door, pull it from the **door frame control** to open it. The door opens and the crystal will be fully exposed to your part to help for its cleaning.
4. After you finish cleaning the glass, close and lock the door by turning the **door frame control** clockwise.
5. Before you lift the door make sure it is securely closed. Do not lift if the door swings, because you may create a crack in the glass.

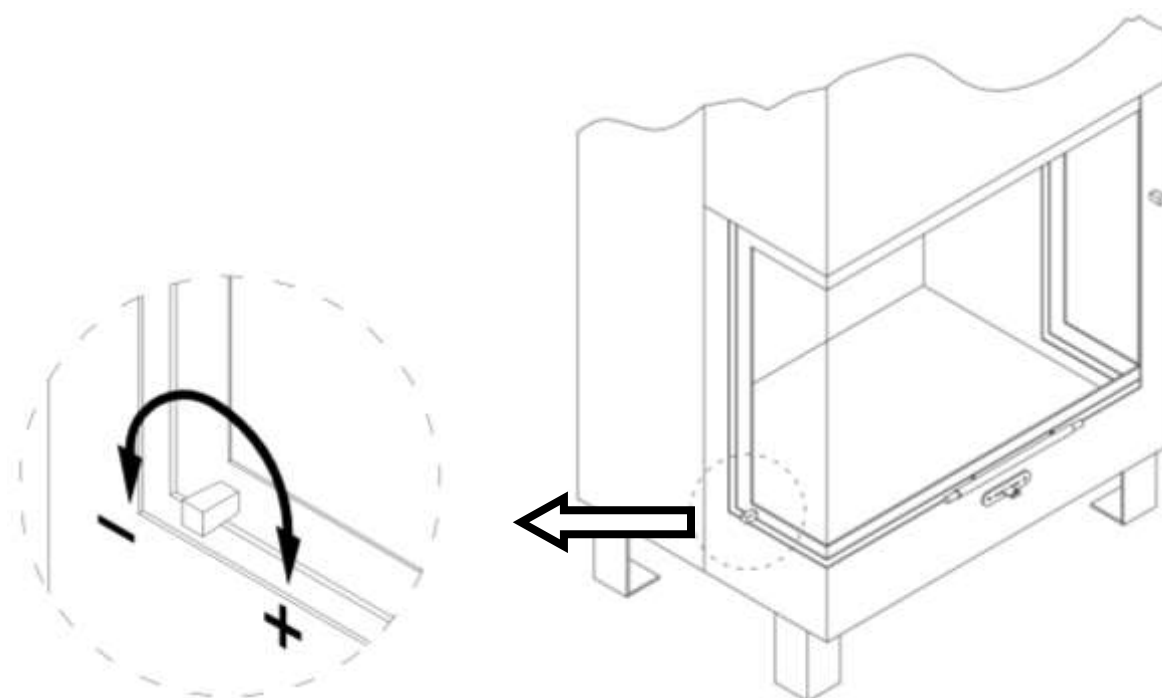

Figure 3: Typical ECO TYPE appliance door frame control

**CAUTION!** To remove the soot you can use special cleaning products for ceramic crystals and absorbent paper. If stains have been created that require sanding to remove, the use of a special scraper for ceramic crystals is allowed, with special care to avoid scratching the crystal.

To clean the crystal, do not use cloths that may scratch the surface or products (e.g. chemicals) that are not suitable for ceramic crystals as they may cause the crystal to become cloudy.

It is **PROHIBITED** to operate the appliance if the door is not properly secured. In this case the combustion chamber is not sufficiently insulated and the appliance may not function properly and flue gases may leak into the installation area.

**NOTE!** The crystal is made of ceramic materials that can withstand temperatures up to 750°C without creating irregularities. Cracks may occur during cleaning if the following rules are not followed or due to mechanical causes due to misuse of the appliance (impact with objects, forced opening or closing of the door, etc.). The warranty does not cover the replacement of the crystal, as long as it cannot be damaged during the proper operation of the device in accordance with the instructions and restrictions of this Technical Manual.

### **13.3 Cleaning the hearth from the ashes**

**CAUTION!** The temperature that the ashtray develops when the hearth is operating as well as for a certain period of time after it is stopped is extremely high.

The ash must be removed from the ashtray regularly. The appliance must not be operated when the ashtray is fully filled as it makes it difficult for air to pass through and causes the grill to overheat.

The ash pan is equipped with a handle that allows it to be operated with the "bare hand" only if the appliance stops working and all its parts, including the ashtray, are sufficiently cooled. Otherwise, the special glove that comes with the appliance should be used.

For cleaning the ashes follow the steps below:

1. Use a small hand vacuum to collect the ashes in an ash pan.
2. Remove the bottom grate at the base of the appliance.
3. Remove the ash pan located beneath the grate.
4. Dispose of the ashes (it is recommended the use of special vacuum for cleaning fireplace ashes). Before disposing of the ashes make sure the ashes have cooled completely and are at room temperature. Otherwise it may cause fire in the container or place intended to be rejected.
5. Replace the empty ash pan to its original position.
6. Replace the grate to its first position.

### **13.4 Maintenance of door sliding guides**

The vertical movement of the door is done through the metal guides on which slides ensuring quiet operation.

To maintain accurate and silent operation of the door the lubricant must be renewed regularly. The lubricant must be suitable for the appliance. To lubricate the drivers follow the steps below:

1. Lift up the door to be fully opened.
2. Find the sliding guides and apply the lubricant according to the instructions of the manufacturer.
3. Close and open the door for several times to spread the oil along the guides.
4. If the movement of the door continues to be difficult or there is noise during operation repeat the process.

#### **CAUTION!**

Do not put too much lubricant to avoid possibility of leakage of the lubricant on the appliance. Prefer more repetitions by spreading a small amount of lubricant.

**14. HANDLING DURING SUMMER**

During the summer months when the appliance is not in use, after cleaning the chimney and the hob, close the regulators and the hob door until the next period of use

**15. DECLARATION OF PERFORMANCE**

See attached documents or [www.tzaki.com.gr](http://www.tzaki.com.gr)

**16. TECHNICAL FICHE**

See attached documents or [www.tzaki.com.gr](http://www.tzaki.com.gr)



FOUNDRY: 7,5<sup>ο</sup> Km THESSALONIKI-KAVALA

FACTORY: PERIVOLAKI LAGADA

T. 0030 23940 20799, 0030 2310 688988

F. 0030 2310 681033

[www.tzaki.com.gr](http://www.tzaki.com.gr)